

PRÓXIMAMENTE

CT B0

CARACTERÍSTICAS

Aplicación	3m - 14 m³ @ 0°C / -		
Compresor	DC rotativo	Evaporador	CT 0 ->
Gas	R134A	Peso condensador	20 Kg
Carga gas	0.7 Kg	Peso evaporador	9 Kg
V compresor	24V	Nº vent. condensador	1
Caudal	900 m³/h	Nº vent. evaporador	1
Desescarche	N/A	V auxiliares	24V
Opción MT	No	Evap. MT	N/A

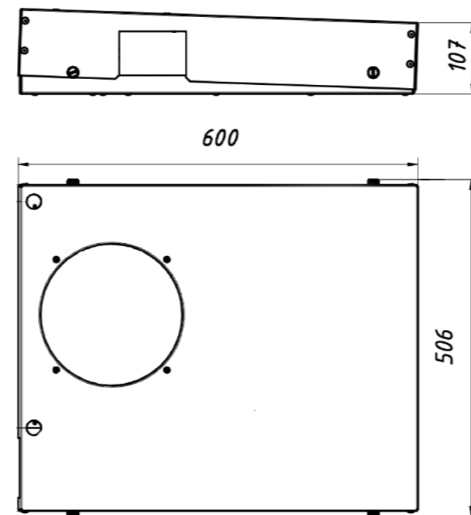

EQUIPAMIENTO



PRÓXIMAMENTE

CT B1

CARACTERÍSTICAS

Aplicación	3m - 14 m³ @ 0°C / 2m - 6 m³ @ -20°C		
Compresor	DC rotativo	Evaporador	CT 1 ->
Gas	R452A	Peso condensador	20 Kg
Carga gas	0.7 Kg	Peso evaporador	9 Kg
V compresor	24V	Nº vent. condensador	1
Caudal	900 m³/h	Nº vent. evaporador	1
Desescarche	Gas	V auxiliares	24V
Opción MT	No	Evap. MT	N/A

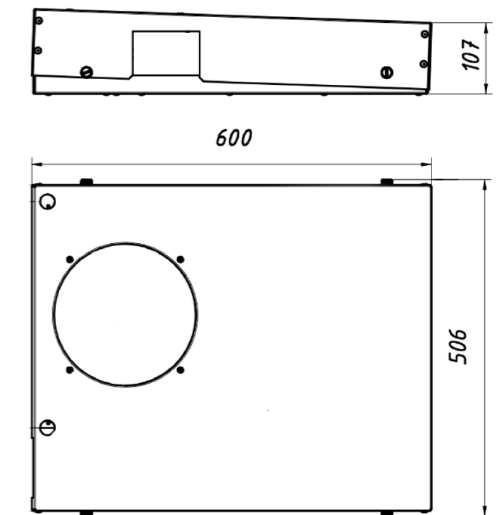

EQUIPAMIENTO

